



BEVERAGE-AIR®

Project: _____	AIA#
Item: _____	
Location: _____	SIS#
Approved: _____	

RB72HC BOTTOM MOUNT: VISTA® SERIES

VISTA® BOTTOM MOUNT REACH-IN REFRIGERATOR

**MODEL:
RB72HC-1S**

RB72HC Solid Door Reach-In Refrigerator
Hydrocarbon Series



**7 Year Parts/Labor Warranty
7 Year Compressor Warranty**

CABINET CONSTRUCTION

- Stainless steel front and doors, gray painted sides
- Gray painted aluminum interior
- Full electronic control
- LED lighting
- Door locks
- Self-closing doors with 120° stay-open feature, on spring-loaded hinges
- One-piece grille allow easy removal/installation for preventative maintenance
- Nine (9) heavy duty epoxy coated wire shelves standard
- 6" Casters standard with (2) brakes

OPTIONS & ACCESSORIES

- Stainless steel universal tray slides (AC)
- Epoxy shelves
- Shelf clips
- 3" Casters or 6" legs
- 6" Flanged/seismic feet
- Remote option* (see note on back page)

REFRIGERATION SYSTEM

- Uses environmentally friendly, energy efficient R290 refrigerant, and meets all regulatory requirements for CARB, SNAP, DOE & more
- Adaptive defrost
- Epoxy coated evaporator coil
- Maintains product temperatures between 36°-38°F



 Please verify qualifying units by visiting:
www.energystar.gov/cfs

3779 Champion Blvd., Winston-Salem, NC 27105
1-888-845-9800 Fax: 1-336-245-6453
Beverage-Air.com Sales@bevair.com



BEVERAGE-AIR®

VISTA® Bottom Mount Reach-In Refrigerator Model: RB72HC-1S

MODEL	RB72HC-1S
EXTERNAL DIMENSIONAL DATA	
Width Overall	75"
Depth Overall with Handle	33 ¾"
Height Overall	84 ½"
Number of Doors	3
Depth with Door Open 90°	55 ¼"
Door Openings (in)	21 7/8" x 52 ¾"
INTERNAL DIMENSIONAL DATA	
NET Capacity (cubic ft.)	70.19
Internal Width Overall (in)	72"
Internal Depth Overall (in)	28 ½"
Internal Height Overall (in)	61 ¾"
Internal Height Useable (in)	55"
Number of Shelves	9
ELECTRICAL DATA	
Full Load Amperes 115/60/1	6.12
REFRIGERATION DATA	
Horsepower	1/2
Capacity (BTU/Hr)	3628
Heat Rejection (BTU/Hr)	5442
Charge (lbs/grams/ounce)	0.2204 / 100 / 3.53
SHIPPING DATA	
Gross Weight (crated lbs)	648 lbs
Height - Crated	87"
Width - Crated	77"
Depth - Crated	36"

*NOTE: Remote units are field wired and come with 6" legs.
Refrigerant must be specified at time of order.

We reserve the right to change specifications and product design without notice. Such revisions do not entitle the buyer to corresponding changes, improvements, additions or replacements for previously purchased equipment. Dimensional tolerances +/- 1/4". Metric dimensions (MM).

Model Views

Required Clearance: Rear 3" & Bottom 3"

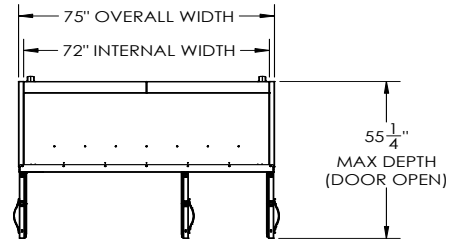

PLAN VIEW

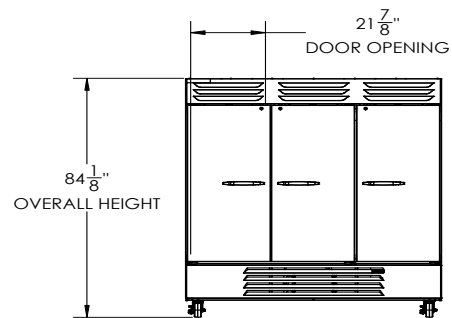

ELEVATION VIEW

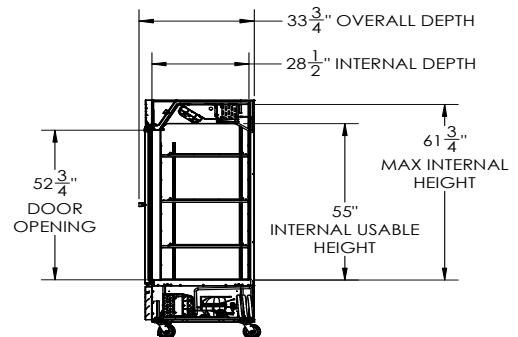

SIDE VIEW

ELECTRICAL CONNECTION



115/60/1
NEMA 5-15P

Unit pre-wired at factory and include 8' long cord and plug set.

