



BEVERAGE-AIR

Project: _____	AIA#
Item: _____	SIS#
Location: _____	
Approved: _____	

WTF20HC WORKTOP FREEZER

SHALLOW DEPTH WORKTOP

WTF20HC Solid Door With Foamed-In Place Backsplash Hydrocarbon Series

**MODEL:
WTF20HC-FIP**



**7 Year Parts/Labor Warranty
7 Year Compressor Warranty**

CABINET CONSTRUCTION

- Stainless steel front, sides, door and grille (galvanized back & bottom)
- Interior liner is made of corrosion resistant aluminum
- Stainless steel top for added durability
- Foamed-in place backsplash
- Full electronic control
- Interior thermometer is standard
- Self-closing door with 120° stay-open feature, on cartridge style hinges
- Door opening includes low wattage, anti-condensate heaters
- Magnetic gasket attached to each door for positive seal
- 6" Casters, two (2) with brakes standard
- Two (2) epoxy-coated steel wire shelves
- Field-reversible door (hinge kit not included)

OPTIONS & ACCESSORIES

- Stainless steel back
- Stainless steel interior
- 16 Gauge stainless steel top
- Additional shelves
- Shelf clips
- Glass door option
- Right or left hinged door
- Locks (solid doors only)
- Bun rack
- Wire shelf divider
- 3" Casters
- 6" Legs (stainless steel, black or seismic/flange)
- Low profile casters
- Roller kit
- Remote option* (see note on back on page)

REFRIGERATION SYSTEM

- Uses environmentally friendly, energy efficient R290 refrigerant, and meets all regulatory requirements for CARB, SNAP, DOE & more
- Adaptive defrost
- Epoxy coated evaporator coil
- Freezers capable of maintaining product temperature of -10°F



Please verify qualifying units by visiting:
www.energystar.gov/cfs

3779 Champion Blvd., Winston-Salem, NC 27105
1-888-845-9800 Fax: 1-336-245-6453
Beverage-Air.com Sales@bevair.com



BEVERAGE-AIR

MODEL	WTF20HC-FIP
EXTERNAL DIMENSIONAL DATA	
Width Overall	20"
Depth Overall with Handle & Bumper	24 1/2"
Height Overall with 6" Casters	36 1/8"
Number of Doors	1
Depth with Door Open 90°	40 3/4"
Door Opening	15 5/8" x 18 1/8"
INTERNAL DIMENSIONAL DATA	
NET Capacity (cubic ft.)	2.34
Internal Width Overall (in)	16"
Internal Depth Overall (in)	8 1/4"
Internal Height Overall (in)	19 1/2"
Number of Shelves	2
ELECTRICAL DATA	
Full Load Amperes	2.5
REFRIGERATION DATA	
Horsepower	1/4
Capacity (BTU/Hr)	857
Heat Rejection (BTU/Hr)	1285.5
Charge (lbs/grams/ounces)	0.0992 / 45 / 1.59
SHIPPING DATA	
Gross Weight - Crated	134 lbs
Height - Crated	35"
Width - Crated	23"
Depth - Crated	26"

*NOTE: Remote units are field wired and come with 6" legs. Refrigerant must be specified at time of order.

We reserve the right to change specifications and product design without notice. Such revisions do not entitle the buyer to corresponding changes, improvements, additions or replacements for previously purchased equipment. Dimensional tolerances +/- 1/4". Metric dimensions (MM).

Worktop Freezer - Shallow Depth Model: WTF20HC-FIP

Model Views

Required Clearance: 3" Bottom & 2" Rear

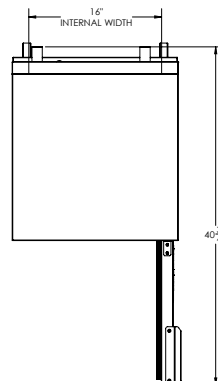

PLAN VIEW

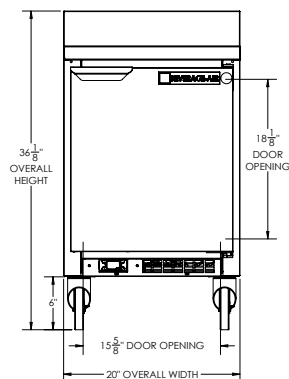

ELEVATION VIEW

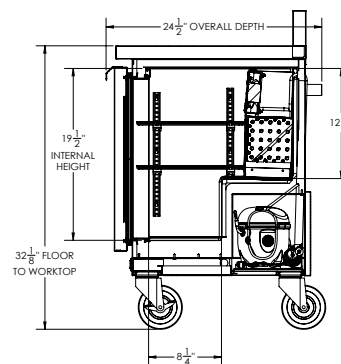

SIDE VIEW

ELECTRICAL CONNECTION



115/60/1
NEMA 5-15P

Unit pre-wired at factory and include 8' long cord and plug set.

