



BEVERAGE-AIR

| | |
|-----------------|------|
| Project: _____ | AIA# |
| Item: _____ | SIS# |
| Location: _____ | |
| Approved: _____ | |

WTFD48AHC WORKTOP DRAWER FREEZER

WORKTOP FREEZER

WTFD48AHC Solid Door Freezer With Drawers Hydrocarbon Series

MODEL:
WTFD48AHC-2



**7 Year Parts/Labor Warranty
7 Year Compressor Warranty**

CABINET CONSTRUCTION

- Stainless steel front, sides, door, drawers and grille (galvanized back & bottom)
- Interior liner is made of corrosion resistant aluminum
- Stainless steel worktop for added durability
- 4" Removable backsplash for flexibility and ease of cleaning
- Full electronic control
- Interior thermometer is standard
- Snap-in drawer gaskets
- Self-closing door with 120° stay-open feature, on cartridge style hinges
- Door opening includes low wattage, anti-condensate heaters
- Magnetic gasket attached to each door for positive seal
- Field-reversible door (hinge kit not included)
- Two (2) epoxy-coated steel wire shelves
- Upper and lower pull-out drawers accommodate 6" deep pans
- Stainless steel drawer frames supported on telescoping drawer slides
- Drawer slides include locking mechanism that prevents drawer from being inadvertently pulled off cabinet
- 6" Casters, (2) with brakes standard

OPTIONS & ACCESSORIES

- Stainless steel back
- Stainless steel interior
- 16 Gauge stainless steel top
- Additional shelves
- Shelf clips
- Right or left hinged door
- Lock (solid doors only)
- Bun rack
- Wire shelf divider
- Cutting board
- 3" Casters
- 6" Legs (stainless steel, black or seismic/flange)
- Low profile casters
- Roller kit
- Remote option* (see note on back on page)

REFRIGERATION SYSTEM

- Uses environmentally friendly, energy efficient R290 refrigerant, and meets all regulatory requirements for CARB, SNAP, DOE & more
- Adaptive defrost
- Epoxy coated evaporator coil
- Freezers capable of maintaining product temperature of -10°F



Please verify qualifying units by visiting:
www.energystar.gov/cfs

3779 Champion Blvd., Winston-Salem, NC 27105
1-888-845-9800 Fax: 1-336-245-6453
Beverage-Air.com Sales@bevair.com



BEVERAGE-AIR

| MODEL | WTFD48AHC-2 |
|------------------------------------|----------------------|
| EXTERNAL DIMENSIONAL DATA | |
| Width Overall | 48" |
| Depth Overall with Handle & Bumper | 32" |
| Height Overall with 6" Casters | 39 5/8" |
| Number of Drawers | 2 |
| Drawer Openings | (2) 19 5/8" x 9 3/8" |
| Number of Door | 1 |
| Depth with Door Open 90° | 52 1/4" |
| INTERNAL DIMENSIONAL DATA | |
| NET Capacity (cubic ft.) | 11.44 |
| Internal Width Overall (in) | 44" |
| Internal Depth Overall (in) | 15 3/8" |
| Internal Height Overall (in) | 23" |
| No. of Shelves | 2 |
| ELECTRICAL DATA | |
| Full Load Amperes | 5.0 |
| REFRIGERATION DATA | |
| Horsepower | 1/2 |
| Capacity (BTU/Hr) | 1868 |
| Heat Rejection (BTU/Hr) | 2802 |
| Charge (lbs/grams/ounces) | 0.165 / 75 / 2.64 |
| SHIPPING DATA | |
| Gross Weight - Crated | 324 lbs |
| Height - Crated | 35" |
| Width - Crated | 51" |
| Depth - Crated | 33" |

*NOTE: Remote units are field wired and come with 6" legs. Refrigerant must be specified at time of order.

We reserve the right to change specifications and product design without notice. Such revisions do not entitle the buyer to corresponding changes, improvements, additions or replacements for previously purchased equipment. Dimensional tolerances +/- 1/4". Metric dimensions (MM).

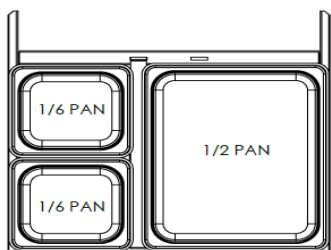

Worktop Freezer Model: WTFD48AHC-2

Model Views

Required Clearance: 3" Bottom & 2" Rear

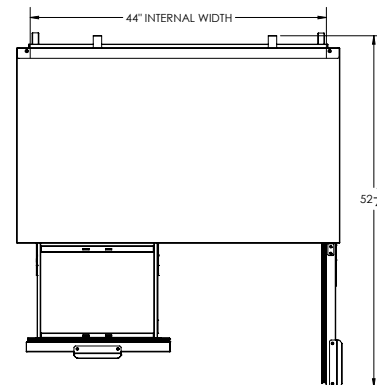

PLAN VIEW

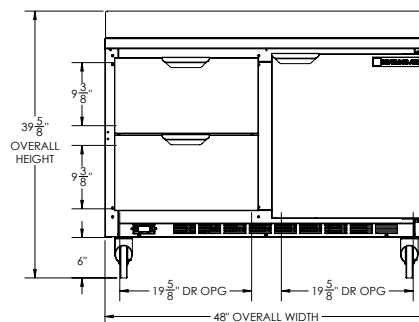

ELEVATION VIEW

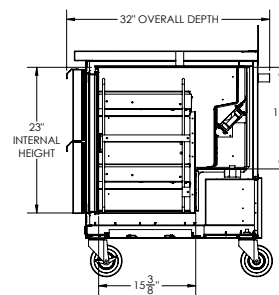

SIDE VIEW

ELECTRICAL CONNECTION



115/60/1
NEMA 5-15P

Unit pre-wired at factory and include 8' long cord and plug set.

