



BEVERAGE-AIR

Project: _____	AIA#
Item: _____	
Location: _____	SIS#
Approved: _____	

WTRD72AHC WORKTOP DRAWER REFRIGERATOR

WORKTOP REFRIGERATOR

**MODEL:
WTRD72AHC-2-FIP**

WTRD72AHC Solid Door Refrigerator With Drawers & Foamed-In Place Backsplash
Hydrocarbon Series



**7 Year Parts/Labor Warranty
7 Year Compressor Warranty**

CABINET CONSTRUCTION

- Stainless steel front, sides, drawers, door and grille (galvanized back & bottom)
- Interior liner is made of corrosion resistant aluminum
- Stainless steel worktop for added durability
- Full electronic control
- Interior thermometer is standard
- Foamed-in place backsplash
- Snap-in drawer gaskets
- Self-closing doors with 120° stay-open feature, on cartridge style hinges
- Door opening includes low wattage, anti-condensate heaters
- Magnetic gasket attached to each door for positive seal
- Field-reversible door (hinge kit not included)
- Four (4) epoxy-coated steel wire shelves
- Upper and lower pull-out drawers accommodate 6" deep pans
- Stainless steel drawer frames supported on telescoping drawer slides
- Drawer slides include locking mechanism that prevents drawer from being inadvertently pulled off cabinet
- 6" Casters, (2) with brakes standard

OPTIONS & ACCESSORIES

- Stainless steel back
- Stainless steel interior
- 16 Gauge stainless steel top
- Additional shelves
- Shelf clips
- Right or left hinged door
- Locks (solid doors only)
- Bun rack
- Wire shelf divider
- Cutting board
- 3" Casters
- 6" Legs (stainless steel, black or seismic/flange)
- Low profile casters
- Roller kit
- Remote option* (see note on back on page)

REFRIGERATION SYSTEM

- Uses environmentally friendly, energy efficient R290 refrigerant, and meets all regulatory requirements for CARB, SNAP, DOE & more
- Adaptive defrost
- Epoxy coated evaporator coil
- Refrigerators capable of maintaining product temperature between 36°F and 38°F



Please verify qualifying units by visiting:
www.energystar.gov/cfs

3779 Champion Blvd., Winston-Salem, NC 27105
1-888-845-9800 Fax: 1-336-245-6453
Beverage-Air.com Sales@bevair.com



BEVERAGE-AIR

MODEL	WTRD72AHC-2-FIP
EXTERNAL DIMENSIONAL DATA	
Width Overall	72"
Depth Overall with Handle & Bumper	32"
Height Overall with 6" Casters	39 5/8"
Number of Drawers	2
Drawer Openings	(2) 19 1/2" x 9 3/8"
Number of Door	2
Depth of Door Open 90°	52 1/4"
INTERNAL DIMENSIONAL DATA	
NET Capacity (cubic ft.)	17.88
Internal Width Overall (in)	68"
Internal Depth Overall (in)	15 3/8"
Internal Height Overall (in)	23"
No. Of Shelves	4
ELECTRICAL DATA	
Full Load Amperes	3.0
REFRIGERATION DATA	
Horsepower	1/5
Capacity (BTU/Hr)	1350
Heat Rejection (BTU/Hr)	2025
Charge (lbs/grams/ounces)	0.2646 / 120 / 4.2
SHIPPING DATA	
Gross Weight - Crated	370 lbs
Height - Crated	44"
Width - Crated	72"
Depth - Crated	35"

*NOTE: Remote units are field wired and come with 6" legs. Refrigerant must be specified at time of order.

We reserve the right to change specifications and product design without notice. Such revisions do not entitle the buyer to corresponding changes, improvements, additions or replacements for previously purchased equipment. Dimensional tolerances +/- 1/4". Metric dimensions (MM).

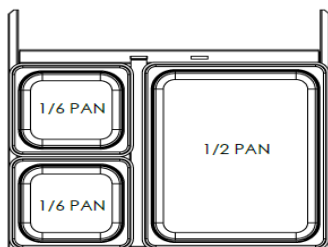

Worktop Refrigerator Model: WTRD72AHC-2-FIP

Model Views

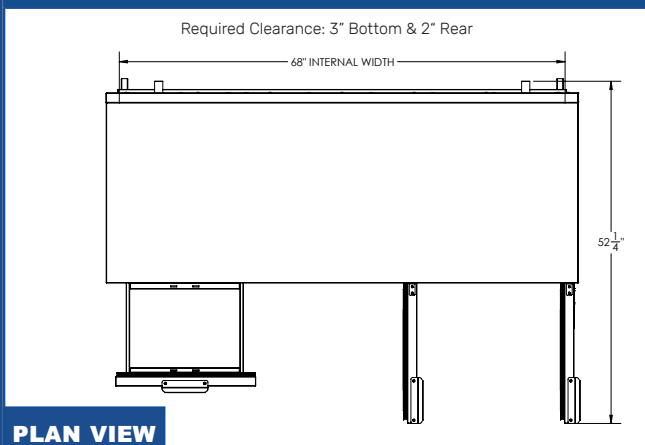

PLAN VIEW

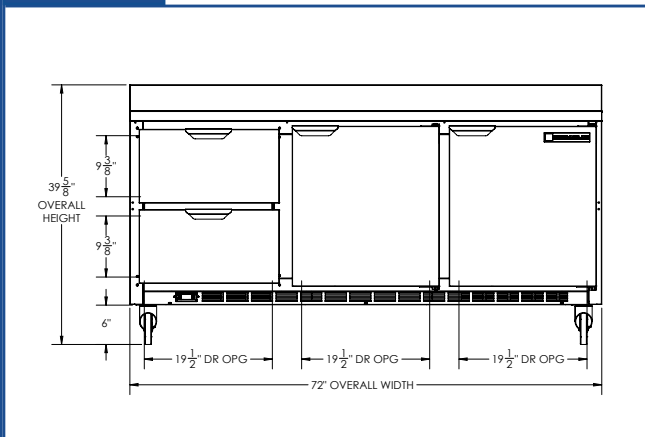

ELEVATION VIEW

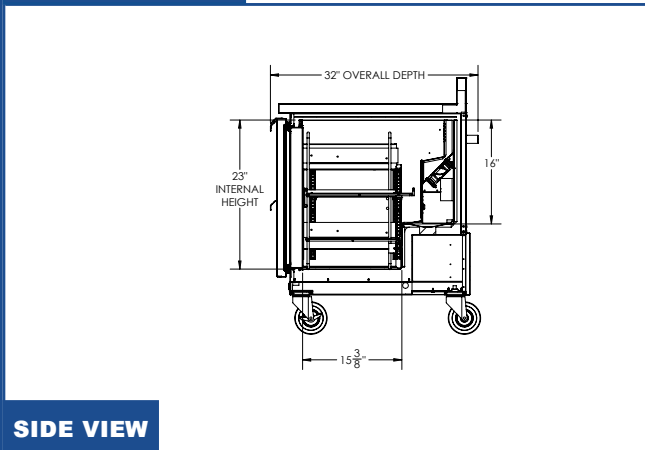

SIDE VIEW

ELECTRICAL CONNECTION



115/60/1
NEMA 5-15P

Unit pre-wired at factory and include 8' long cord and plug set.

