

# MOTAK

## Double Full Size Gas Convection Oven Model #: MDCO-2-N

### Product Details

#### Construction

- Stainless Steel Front and Angular Legs
- Double pane thermal glass windows on doors
- Steel legs with adjustable bullet feet
- Doors have an interlock switch that automatically turns the fan and burners off when open
- 3/4" rear NPT gas connection

#### Oven Features

- Easy to Clean Full Porcelain Oven Interior.
- Oven interior measures 29" x 26" x 20" Sheet pans will fit left to right or front to back!
- 1/2 HP two speed fan motor
- Cooking chamber is lined with porcelain enamel
- 10 position guide rack with 1.5" spacing in between
- 5 heavy duty adjustable chrome plated racks
- Seamless interior and corners for easy cleaning

#### Controls

- Accurate solid state oven thermostat with a range from 150°F - 550°F
- 60 minute continuous ring timer - manual shut off
- Temperature ready indicator light
- 6' power cord with NEMA 5-15 Plug

Not suitable for installation in non-commercial or residential applications.



### Plan View

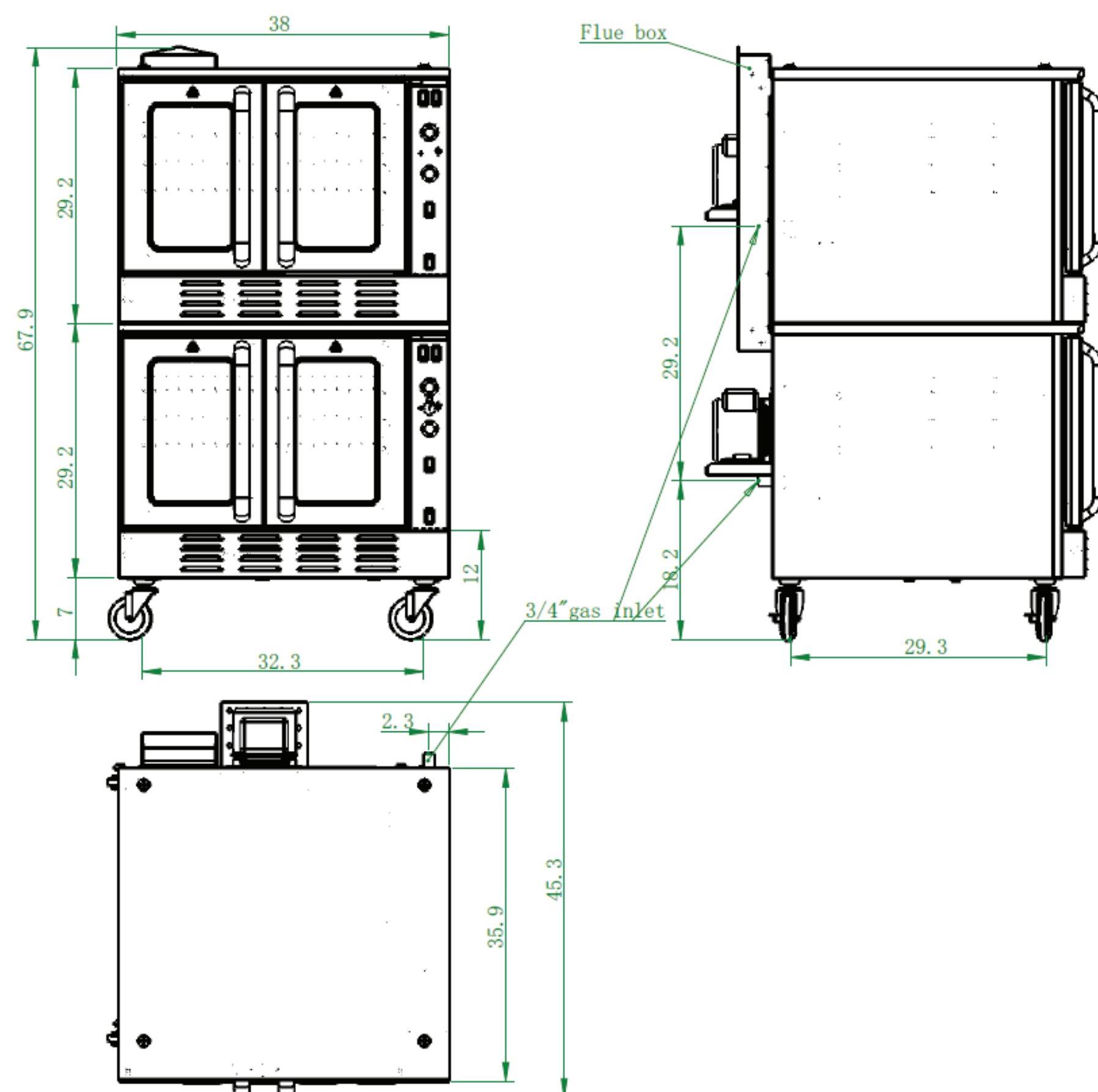

### Specifications

Model	Racks	External Dimensions			Internal Oven Dimensions			Total BTU's	AMP	Volts
		W	D	H	W	D	H			
MDCO-2-N	10	38	43.5	68	29	26	20	108,000	5.9	120V