

## "2B-2D" B-SERIES COMPARTMENT SINKS

### 2 Compartment w/2 Drain Boards - 16GA w/Stainless Steel Base

#### FEATURES:

- 16GA Stainless Steel
- Type 300 Stainless Steel w/#4 Polish, Satin Finish
- 14" Deep Bowls
- All Corners, Both Vertical & Horizontal, Coved At 3/4" Radius
- Bottoms Of Bowls Formed For Drainage To 3-1/2" Diameter Die Stamped Opening
- Full Length 10" High Boxed Backsplash, w/2" Return To Wall At 45 Degree & 1" Turned Down Rear Lip
- 1" Faucet Holes In Backsplash
- All Outside Corners Of Assembly Are Bullnosed To Provide Safe, Clean, & Polished Edge
- Standard Stainless Steel Legs 1-5/8" Diameter

#### SPECIFICATIONS:

- Top: Stainless Steel Sinks Are Tig Welded, Exposed Welds Are Polished To Match Adjacent Surface
- Base: Stainless Steel Bases Are Mig Welded
- Bowls & Top: 16GA Type 300 Stainless Steel w/#4 Polish, Satin Finish
- Legs: 1-5/8" Round O.D. Stainless Steel
- Bracing: 1-1/4" Round O.D. Stainless Steel
- Gussets: Stainless Steel
- Feet: 1" Adjustable Stainless Steel Bullet Feet

#### CERTIFICATIONS:



2B18244-2D18

#### ACCESSORIES

MODEL
Faucets
Add-A-Faucets
Pre-Rinse Units
Lever Waste
Overshelves
Pot Rack

#### "2B-2D" B-SERIES SINKS

14" DEEP (D')	OVERALL LENGTH (L)	OVERALL WIDTH (W)	INSIDE LENGTH (L')	INSIDE WIDTH (W')	A	B	C	WT. (LBS)
2B16204-2D18	71-1/4"	25-1/2"	16"	20"	12-15/16"	31-5/8"	18"	95
2B184-2D18	75-1/4"	23-1/2"	18"	18"	11-15/16"	33-5/8"	18"	95
2B18244-2D18	75-1/4"	29-1/2"	18"	24"	14-15/16"	33-5/8"	18"	109
2B244-2D24	99-1/4"	29-1/2"	24"	24"	14-15/16"	45-5/8"	24"	132

ALL DIMENSIONS ARE TYPICAL. TOLERANCE +/- .500". JOHN BOOS & CO. RESERVES THE RIGHT TO CHANGE SPECIFICATIONS WITHOUT NOTICE.

# DETAILED SPECIFICATIONS

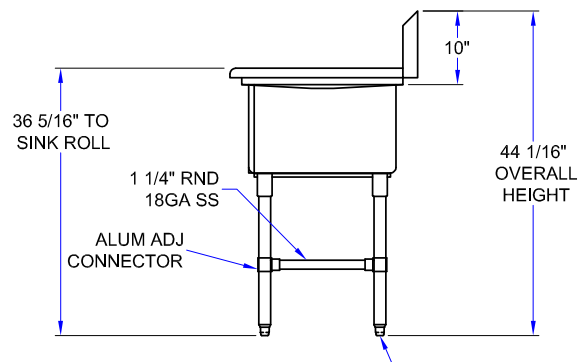
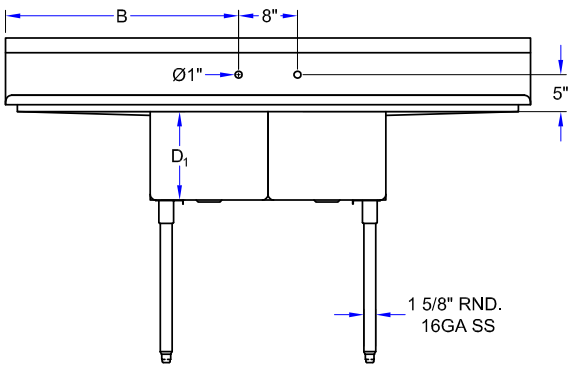
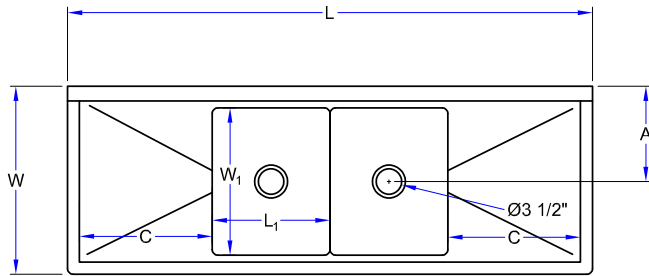

## "2B-2D" B-SERIES SINKS

14" DEEP (D')	OVERALL LENGTH (L)	OVERALL WIDTH (W)	INSIDE LENGTH (L')	INSIDE WIDTH (W')	A	B	C	WT. (LBS)
2B16204-2D18	71-1/4"	25-1/2"	16"	20"	12-15/16"	31-5/8"	18"	95
2B184-2D18	75-1/4"	23-1/2"	18"	18"	11-15/16"	33-5/8"	18"	95
2B18244-2D18	75-1/4"	29-1/2"	18"	24"	14-15/16"	33-5/8"	18"	109
2B244-2D24	99-1/4"	29-1/2"	24"	24"	14-15/16"	45-5/8"	24"	132

ALL DIMENSIONS ARE TYPICAL. TOLERANCE +/- .500". JOHN BOOS & CO. RESERVES THE RIGHT TO CHANGE SPECIFICATIONS WITHOUT NOTICE.