

MOTAK

Wine Cooler

Model #: **MXW-170WE**

Product Details

- Uses R600a Refrigerant, which is eco-friendly and more efficient
- Refrigeration System maintains temperature between 37°F and 65°F
- Interior BLUE LED lighting for better viewing of your offerings
- Dual Digital temperature control (Upper & Lower) to adjust to the correct temperature of your needs on either side of the cooler for your specific needs
- Swing Glass Door, stainless steel door frame, stainless steel handle
- Magnetic Door Gaskets, easily removed for cleaning
- Wire shelves are adjustable PVC coated
- Exterior: Black Coated Steel and the interior is HIPS material, black
- Four (4) leveling feet included
- Frost free design

Not suitable for installation in non-commercial or residential applications.

Warranty

WARRANTY: 1 year parts and labor

Certifications



Intertek

Specifications



Plan View

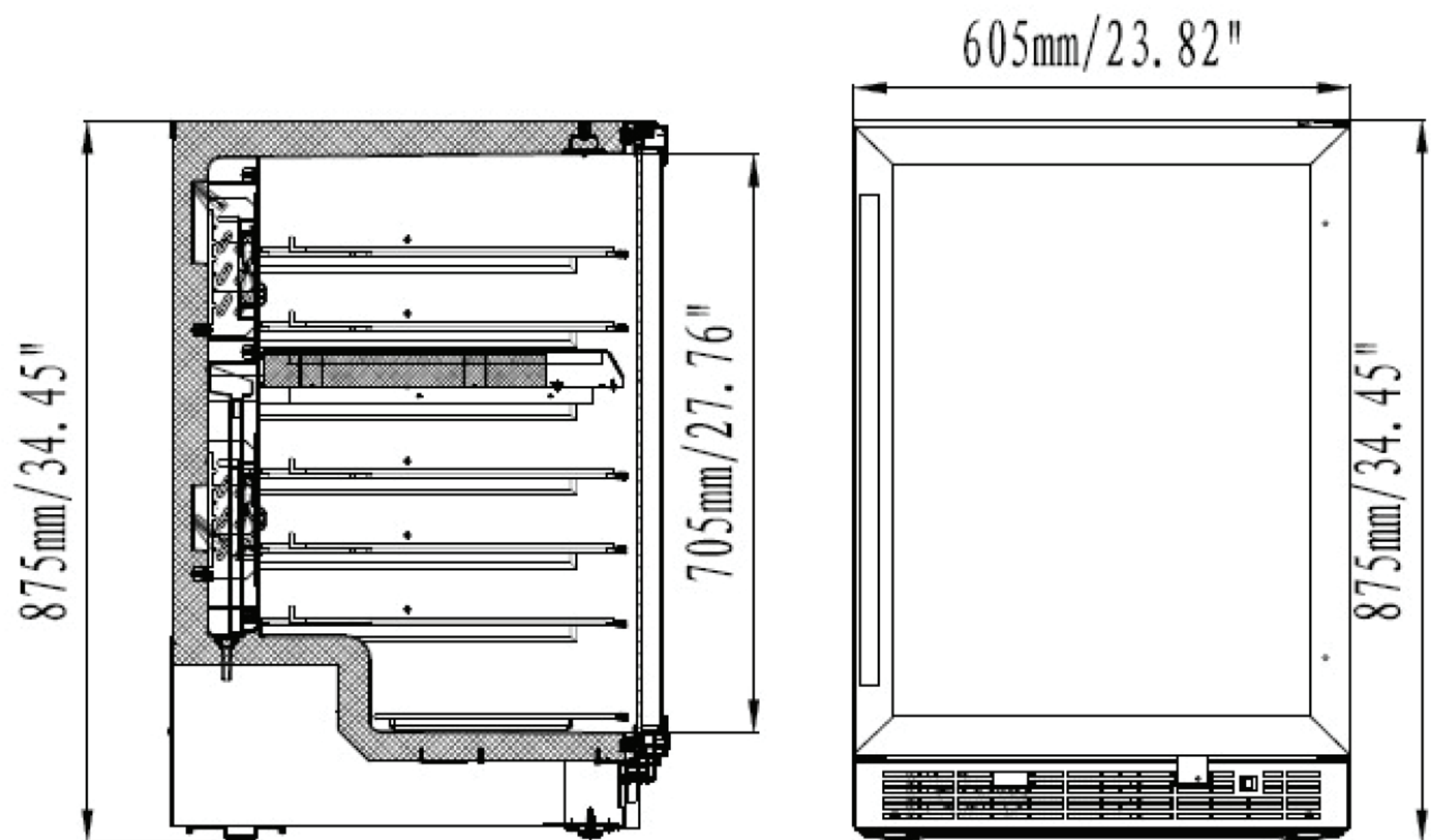

Model	Shelves	Bottles Quantity	Storage CAP (Cu-ft)	Cabinet Dims (in)			HP	Voltage	Amp	NEMA Plug	Cord Length (ft)	Crated Weight (lbs)
				W	D	H						
MXW-170WE	6	51	5.5	23.8"	23.2"	34.5"	1/6	115/60/1	2.1	5-15P	5 ft.	114/125 lbs.

MOTAK reserves the right to make changes to the design or specifications without prior notice.